



2020.09.25

(688396)

81.07

81.07

55.19

www.crmicro.com

1.		4
2.	MOS		
		5
2.1.			
	6		
2.2.		6
2.3.		8
2.3.1.		8
2.3.2.	MOSFET	9
2.3.3.	&		
	11		
2.4.		12
3.	IGBT	IGBT	
	15		
3.1.		15
3.1.1.	IGBT	15
3.1.2.		17
3.2.		19
3.2.1.		IGBT	
		19
3.2.2.		+ IGBT 20
3.2.2.1.	IGBT		
	IGBT	20
3.2.2.2.	IGBT		
		IGBT 23
3.2.2.3.		+ IGBT 25
4.		25
5.		26
6.		27

1.

1
2

MOS 2020 4
 IGBT
 1 MOSFET
 IGBT
 MOSFET IGBT SBD FRD
 IOT
 2
 a MOSFET
 b IGBT MOS VDMOS MOS
 600V-6500V IGBT Trench-FS
 Trench c SBD 8
 FRD d
 e BCD
 5-700V BCD BCD SOI
 BCD
 f MEMS
 g IPM

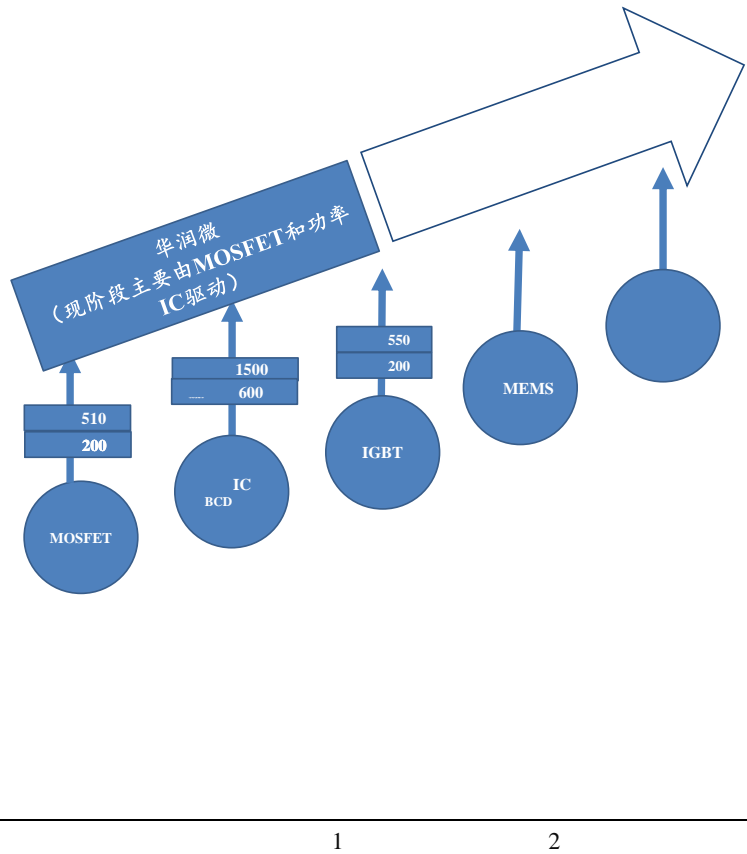
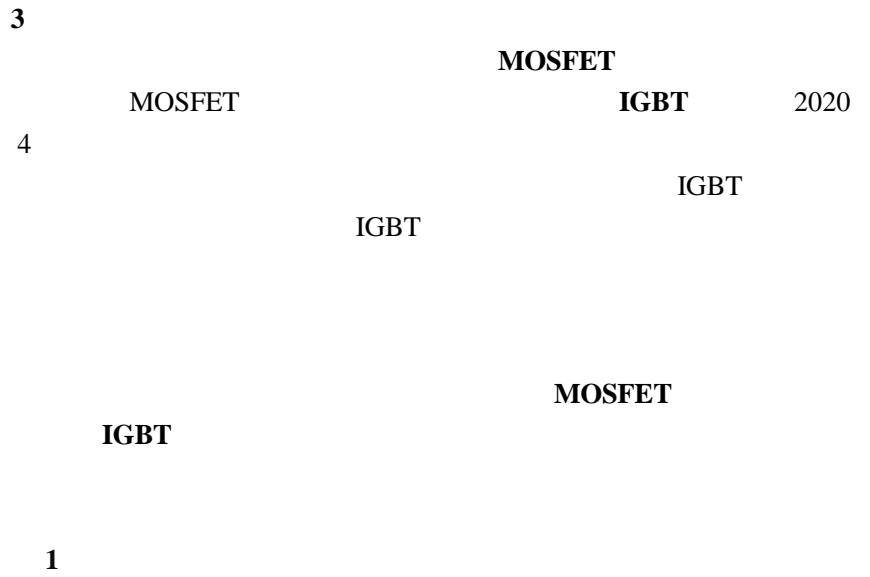

2.

MOS

MOSFET

70%

MOS
MOSFET

2.1.

MOSFET

6-16 MOSFET
9 MOSFET

MOSFET **10**
20 **+100%**

1

MOS MOSFET

MOS

MOS

6

9 12 16

2

MOSFET

MOS
PCM
MOS

PCM
PCM

6-9

2

MOS

3

MOS

9

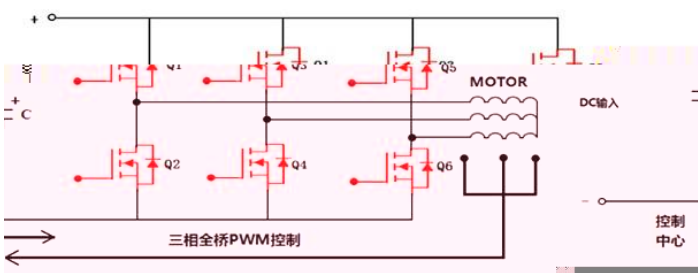

6

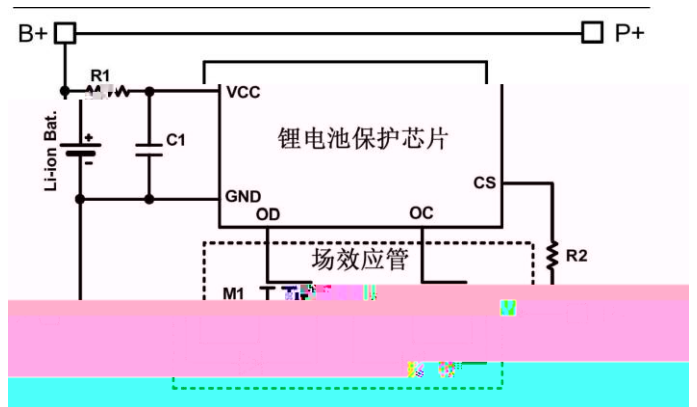

2.2.

2014-2019

2020

1 2014-2019

2005-2013	2014-2017	2018-2019
2013	/	6-7 2012-
-3600	2	3100
67.7 /	2016 57.7 /	2019
57 /	2016 49.7 /	2019

4 2014-2019

5
3 / / 2 /

2005-2019

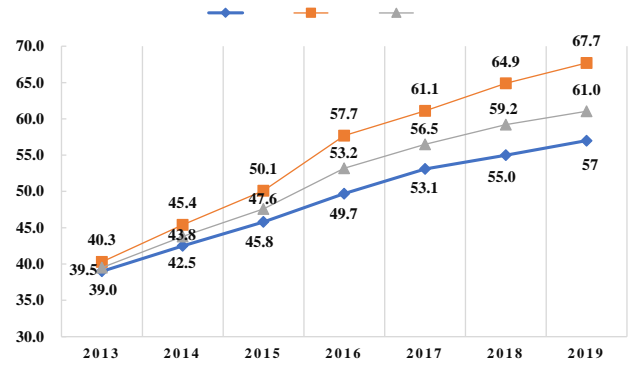
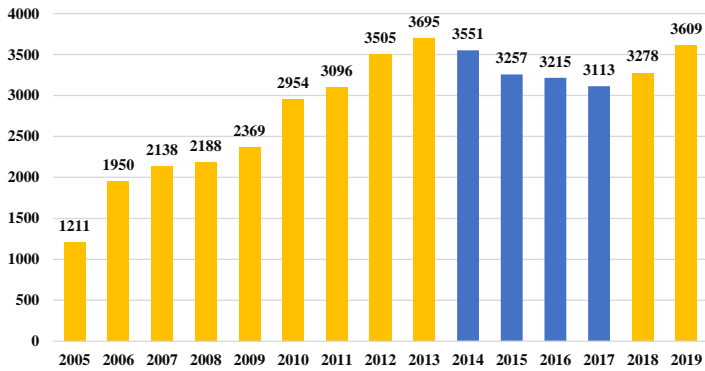

2020

2.3

7

20%

2019

MOSFET

20Q2

Q2

821.2

120% 7

374.1

22.7%

21.7%

MOSFET

MOSFET

6

7

20%+

2019

一张图看懂新国标



机动车			类别	非机动车
GB/T24159-2018	GB/T24159-2018	GB/T24159-2018	电动自行车	GB17761-2018
2019.04.15	2019.04.01	2019.04.01		标准实施时间
✗	✓	✓		电摩生产资质
✓	✓	✓		3C认证
✓	✗	✗		脚踏骑行功能
≤25km/h	≤50km/h	>50km/h		最高车速
≤400w	400w-4kw (非强制)	可大于4kw		电机功率
≤55kg		可≥55kg		整车质量
≤48V		无限制		电池电压
因地而异	不能载人	可载一名成人		能否载人
✗	✓	✓		驾驶证
智能电子牌照	蓝牌	黄牌		牌照

2.3.2. MOSFET

2019 13% 2020

1

2

VRLA

2019 13%

8 2019 13%

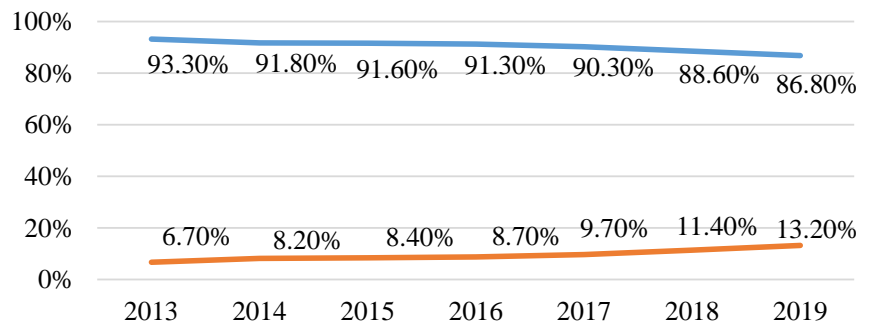

ZDC

1

2019 4

55kg

20AH

1/3

48V+12AH

48V+15AH

48V+20AH

48V+24AH

2

2020

2.3.3.

&

				2020		
			2020	2		320
	37.27		2020	4		
Q8		2020	6			
	400	300	100		2020	
					2019	100
		2025	800			
2019	2019	2019	8			
1950		360				
	2019	100		2025	800	2020-
2022				150	200	250

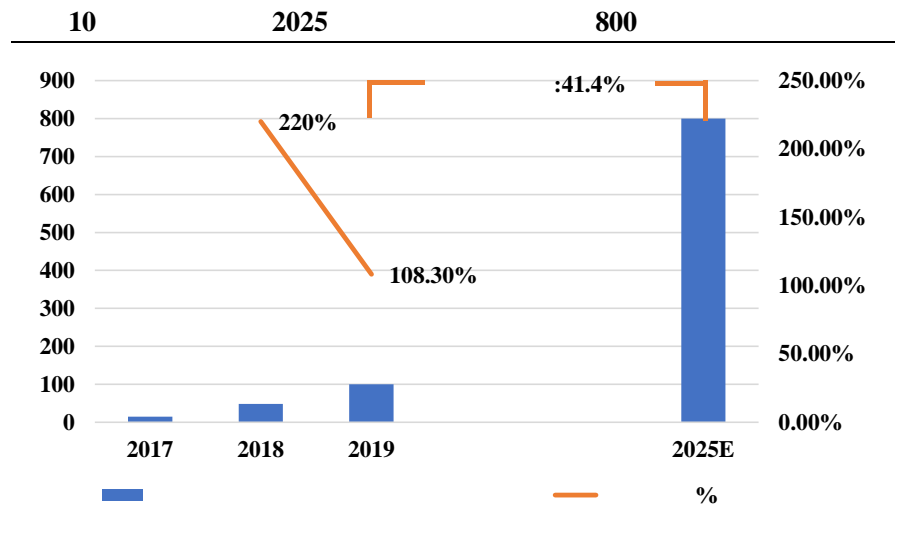

	5	2020-2025		3000
2018		136.5	2017	58%;
2019	193.4	2018	41.6%;	
2020	228.4	2019	18.1%	2021

313.6 37%

399 2020 2019
1 5 120

2019 KA 60

11 2014-2021

2014-2021

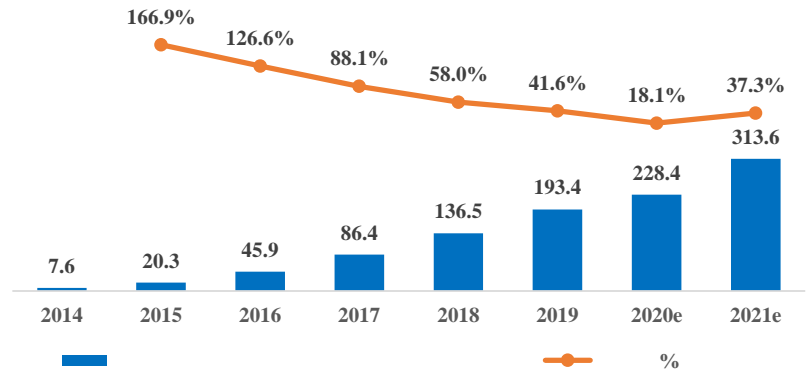

2.4.

2020-2022

1 2
3 4
8
12.5 % 2020-2022
37.5%
2020-2022

1

2021-2022

2.8

57

1.54

2020-2022

37.5%

75%

15% 25%

35%

25%

40% 60%

2 /

2020-

2022

2.2 /

616

2

1.7

70

1.2

2020-2022

37.5%

55%

13%

15%

22%

25% 40% 50%

3 /

2020-

2022

3.2 /

544

3

4

MOSFET

2020

40%

9

2021

14.2

YOY+55%

,2022

21.2

YOY-

75%

2020 -2022

7 10.6 15.9

MOSFET

2020E

E

%	75%	60%	40%
	2257.5	2763.6	2480.8
2			
a	780	900	1320
b	544	544	544
%	25%	40%	50%
	331	577.6	932
%	75%	60%	50%
	993	866.4	932
3			

3. IGBT IGBT

2020 4

+
IGBT + IGBT IGBT +

IGBT

+
IGBT

IGBT
+

+
IGBT

IGBT

1

15

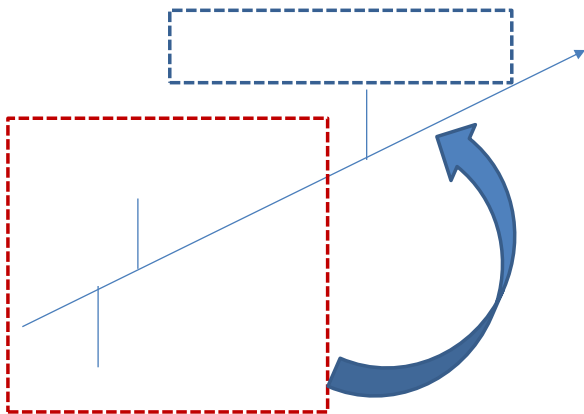

16

18%

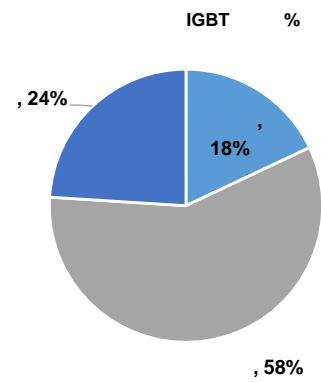

17

IGBT

18

		IGBT		
			IGBT	
IGBT		200		IGBT
	22		10%	11%
21	IGBT	2020	22.4	

	IHS		
		IGBT	2020
1128			
			1000
800			
		2019	
22			6

IGBT	%	7.78	9.17	10.80	12.72	14.97	17.60	20.69
	%	0%	0.5%	20%	30%	40%	50%	60%
IGBT		0.00	0.05	2.16	3.82	5.99	8.80	12.41

Yole

3.2.2.2. IGBT
IGBT



22 14% 23 21%

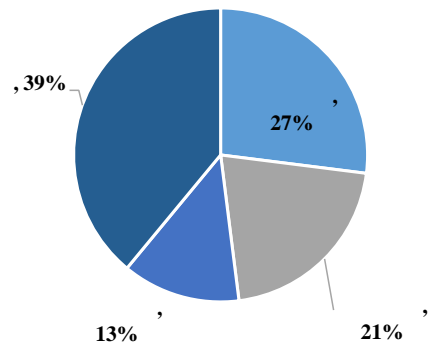
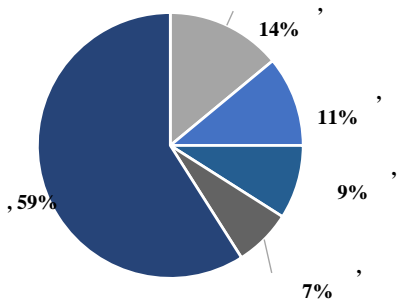

2020 IGBT 1.12
2021 1.58 2025 6.13 2020-2025

CAGR=40%

IGBT

2020-2025

1% 10% 20% 30% 40% 50%

IGBT

2021

0.16

2025

3.68

5

IGBT



		IGBT	0.84	1.12	1.58	2.19	3.04	4.21	6.13
		%	0%	0.5%	20%	33.04			

9.75% 10.58% 8%

2 2020H2 2021 MOSFET

MOSFET IGBT

IDM 2020-2022

28.20% 22.92% 34.20%

28.20% 19.79% 32%

2020/2021/2022 17%/18%/22%

2020/2021/2022 27.20%/29.50% /31.90%

2020-2022 8.27 11.02 14.97

106% 33% 36% EPS 0.68 0.91 1.23

0.68 0.88 1.18

7

		2017	2018	2019	2020E	2021E	2022E
		3519.76	3571.91	3183.52	3493.91	3964.24	4352.74
	%	59.90%	56.96%	55.44%	52.00%	50.00%	45.00%
	%		1.48%	-10.87%	9.75%	13.46%	9.80%
	%	16.33%	18.57%	17.76%	20.00 %	22.00%	22.00%
		2339.06	2683.49	2515.66	3225.15	3964.24	5320.01
	%	39.81%	42.79%	43.80%	48.00%	50.00%	55.00%
	%		14.73%	-6.25%	28.20%	22.92%	34.20%
	%	19.59%	34.02%	29.48%	35.00%	37.00%	40.00%
		16.77	15.40	43.60	0.00	0.00	0.00
	%	0.29%	0.25%	0.76%	-	-	-
	%		-8.17%	183.12%	-	-	-
	%	14.00%	28.46%	10.04%	-	-	-
		5875.59	6270.80	5742.78	6719.05	7928.48	9672.75
	%		6.73%	-8.42%	17.00%	18.00%	22.00%
	%	17.62%	25.21%	22.84%	27.20%	29.50%	31.90%

wind

5.

A IDM

DFN/QFN SGT MOS

SBD JBS

PB PS
IDM
IGBT
29%

PB		2020	PB	7.25	2020
9.33	PB	81.07			
PS		2020	PS	14.27	2020
	PS	101.40			18.35

81.07

8 **2020 9 23**

			P/S 2020E)				PB		
				2020E	2021E	2022E	2020E	2021E	2022E
300623.SZ		36.45	20.56	4.80	5.32	6.10	7.59	6.85	5.98
300373.SZ		41.78	7.98	6.05	6.80	7.80	6.91	6.14	5.36
			14.27	-			7.25	6.50	5.67

wind

wind

6.

受

交 或 交 受 受 交 或 受 受 受 受 他 他 平 受 平 平 受 受 刊 或 受 或 受 受 受 受 受 受 了 受 个 平 受 受 受 受 平 平 交 受 有 受 受 平 受 受 个 或 受 个 或

受 他 受 他 个

取 取 事 取

@ @ @ @